

FXbend **cell**

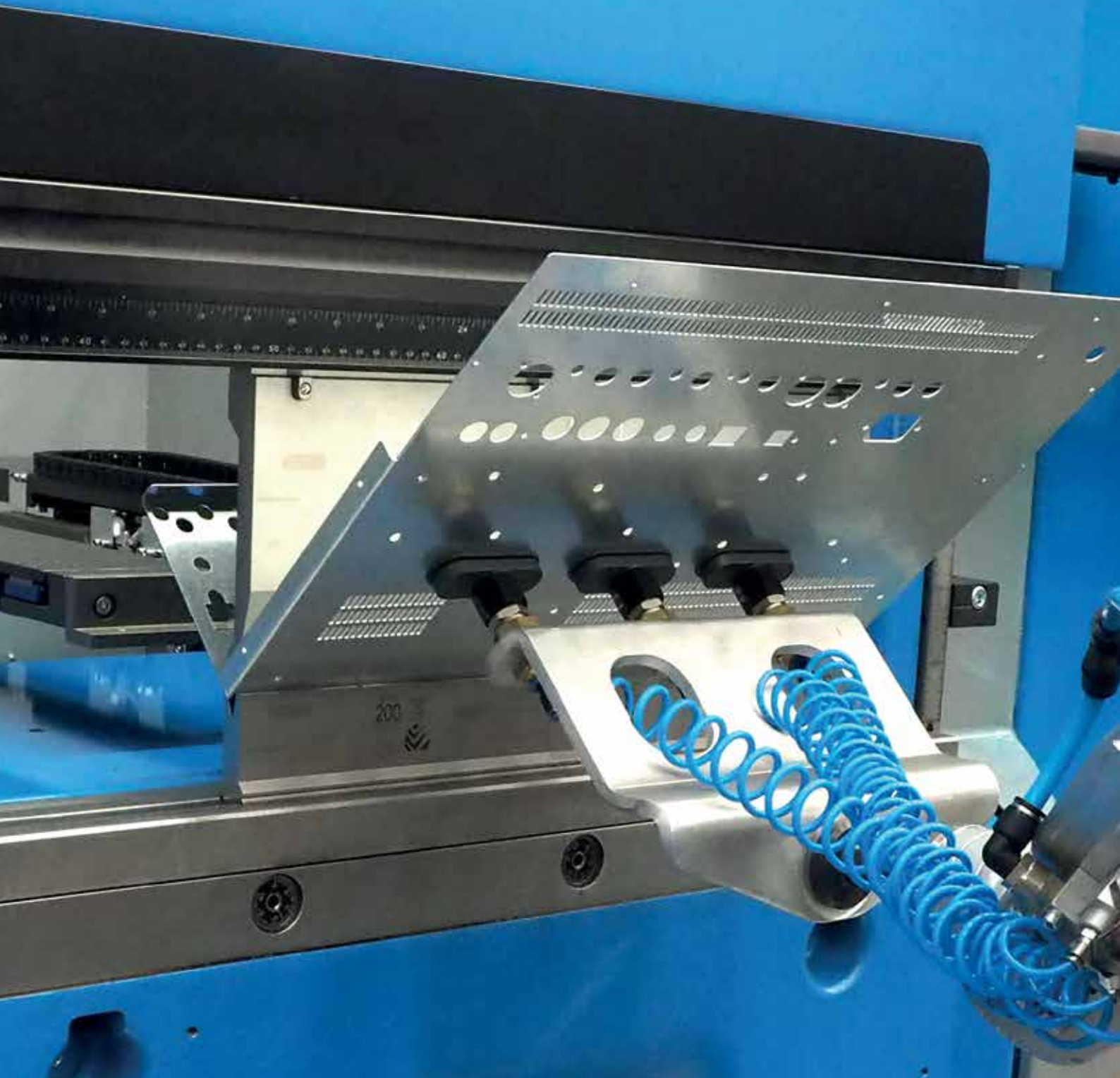

automated electric
press brake

EUROMAC®

general catalogue

The cell was created with a variety of bending applications in mind, but more specifically **yours!**



Short programming time

With our Fx Cell 3D software, it is possible to program the robot off-line in very short time.

Active Fingers

For an accurate repeatability of the pieces with self-learning mode.

Plug and play Bending Cell

System completely realized by Euromac

Euromac provides a complete solution, designing and developing every single element of the structure, from the machine and the robot integration, to the software that runs the production.

A complete, reliable and friendly-use system.



We configure the machine to your individual specification:

MAX - MAX 7 (7 Axes Robot)

Cell for small and medium sized pieces with a high production capacity.

The cell is integrated by:

- Fx Bend with 6-axis backgauge
- Robot Kuka KR10 cybertech nano
- Base of the robot integrated into the machine
- Turnover system
- Double part control
- Loading station with 2 tables of 1200 x 800 mm
- Unloading:
 - Palletization on a motorized roller conveyor for Europallet
 - Vertical storage up to 10 Europallets (optional)
 - Automatic belt with unloading into a box (optional)
- Also available with 7 axes robot (MAX).

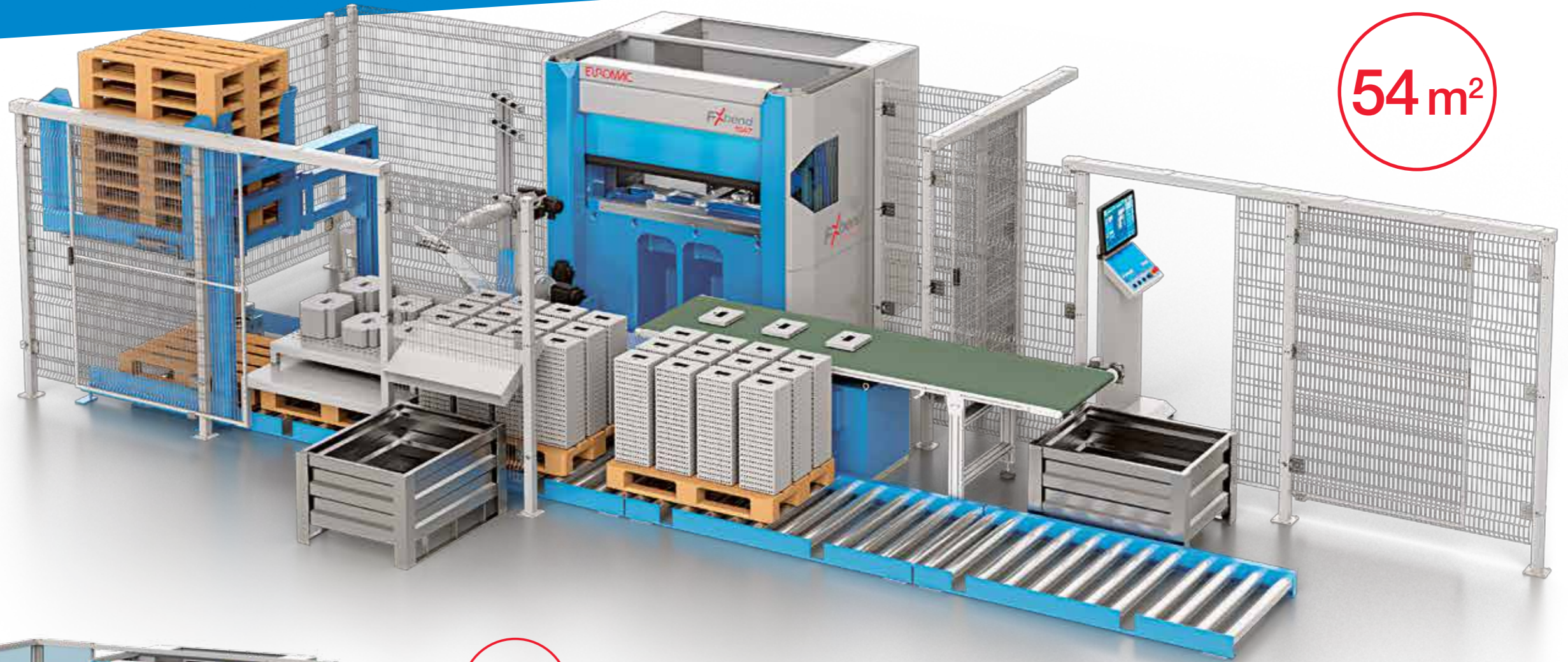

54 m²



30 m²

PLUS

Cell for small and medium sized pieces with a high production capacity.

The cell is integrated by:

- Fx Bend with 6-axes backgauge.
- Robot Kuka KR10 cybertech nano.
- Base of the robot integrated into the machine
- Centering table
- Turnover system

- Double part control
- Loading station with 2 tables of 1200 x 800 mm
- Unloading:
 - Palletization on a Europallet
 - Automatic belt conveyer together with motorized roller conveyor for multi boxes.

STANDARD

Cell for small and medium sized pieces with a high production capacity.

The cell is integrated by:

- Fx Bend with 6-axes backgauge
- Robot Kuka KR10 cybertech nano
- Base of the robot integrated into the machine
- Turnover system
- Double part control
- Loading station with 2 tables of 1200 x 800 mm
- Unloading:
 - Palletization on a Europallet
 - Automatic belt conveyer for unloading into a box (optional).

23 m²



64 m²

The ideal solution for workpieces up to 1500 x 800 mm. Large-capacity robot, with 2 different unloading configurations that can be modulated based on the customer productivity.

MAX

Cell for small and medium sized pieces with a high production capacity.

The cell is integrated by:

- Fx Bend with 6-axes backgauge
- Robot Kuka KR60
- Base of the robot integrated into the machine
- Centering table
- Turnover system
- Double part control
- Loading station with 2 tables of 1500 x 800 mm
- Unloading:
 - Vertical storage for 10 Europallet (optional)
 - Palletization on a motorized roller conveyor for Europallet
 - Boxes for small pieces
 - Automatic belt conveyer for unloading into a box (optional).



50 m²



STANDARD

Cell for small and medium sized pieces with a high production capacity.

The cell is integrated by:

- Fx Bend with 6-axes backgauge
- Robot Kuka KR60
- Base of the robot integrated into the machine
- Centering table

- Turnover system
- Double part control
- Loading station with 2 tables of 1500 x 800 mm
- Unloading:
 - Palletization on 2 Europallet
 - Automatic belt conveyer for unloading into a box (optional).

Large-scale robot, available in 2 unloading configurations suitable to your productive needs.

60 m²

MAX

Cell for medium and large sized pieces with a high production capacity.

The cell is integrated by:

- Fx Bend with 6-axes backgauge
- Robot Kuka KR60 on rail
- Centering table
- Turnover system
- Double part control
- Loading station for pieces up to 2500 x 1000 mm
- Unloading:
 - Vertical storage for 10 Europallet (optional)
 - Box for small pieces
 - Palletization on motorized roller conveyor for Europallet.



50 m²

STANDARD

Cell for medium and large sized pieces with a high production capacity.

The cell is integrated by:

- Fx Bend with 6-axes backgauge
- Robot Kuka KR60 on rail
- Centering table

- Turnover system
- Double part control
- Loading station for pieces up to 2500 x 1000 mm
- Unloading:
 - Palletization on 6 Europallet.

SOFTWARE

ON LINE
Standard software
with parametrized
programs.

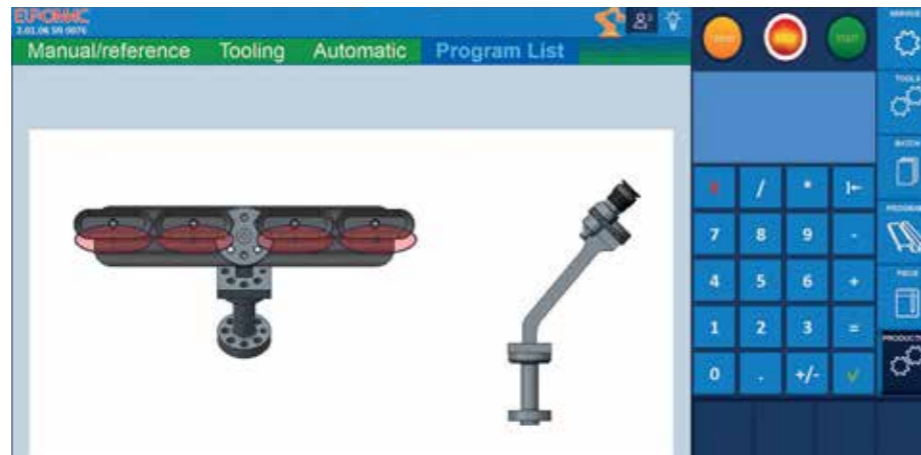

FX CELL Supervisor

The added value is the extreme ease and speed in making any kind of modification to your work.

With Fx Cell supervisor it is possible to:

- modify all the parameters of the bending cells
- choose the right gripper and activate or deactivate the suction cups
- select or modify the loading part position
- select or modify the unloading position
- activate or deactivate the double metal sheet control

All this, working directly from the interface of our Fx Soft and without having to change anything from the program.

Everything at your fingertips in a simple and fast way.

Possibility to put the robot in parking mode to work in manual mode inside the cell.



SOFTWARE

OFF LINE
FX CELL 3D
Software optional

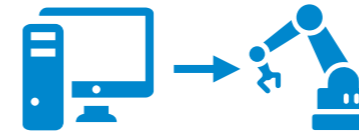

Easy and fast programming time even for more complex requirements.

The offline programming software works in perfect cohesion with the FX bend cell, becoming a complementary optional item allowing to quickly anticipate the movements, the processing efficiency and eventually acting to optimize it. Thanks to a 3D graphic display and the management of the palletization data, it's possible to have a complete operation vision and reduce production times.

With Fx Cell 3D software we can assure that in the great majority of the pieces it is not necessary to touch the teaching pad.

- Reduce production stops due to programming time to a minimum.
- Predict the efficiency of the workcell for any particular product and take action to improve it if necessary.
- Simplify robot programming task.
- Easily visualize and setup palletizing data.

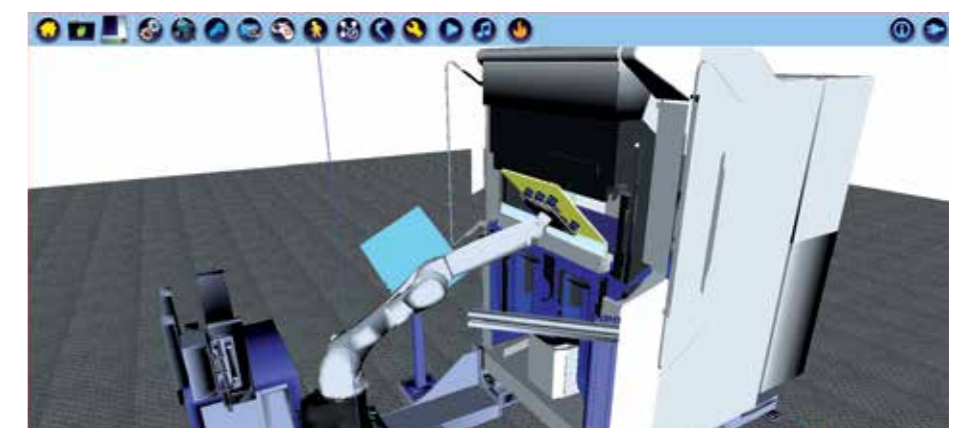
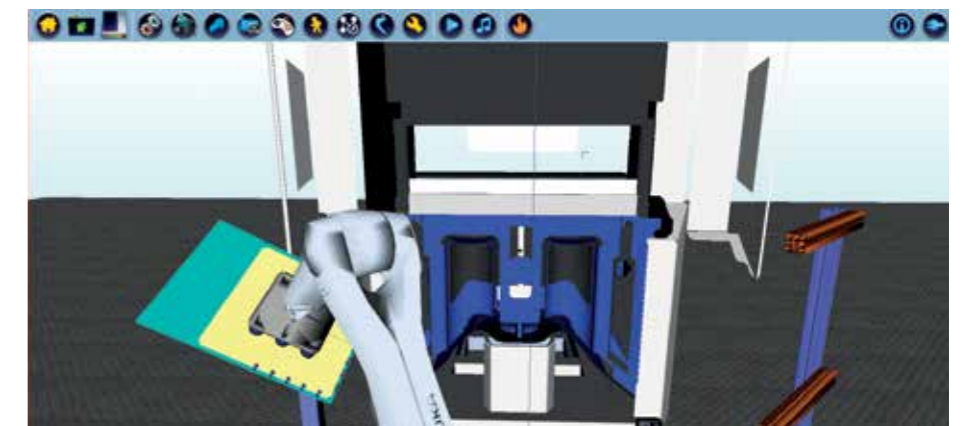

LOADING & UNLOADING

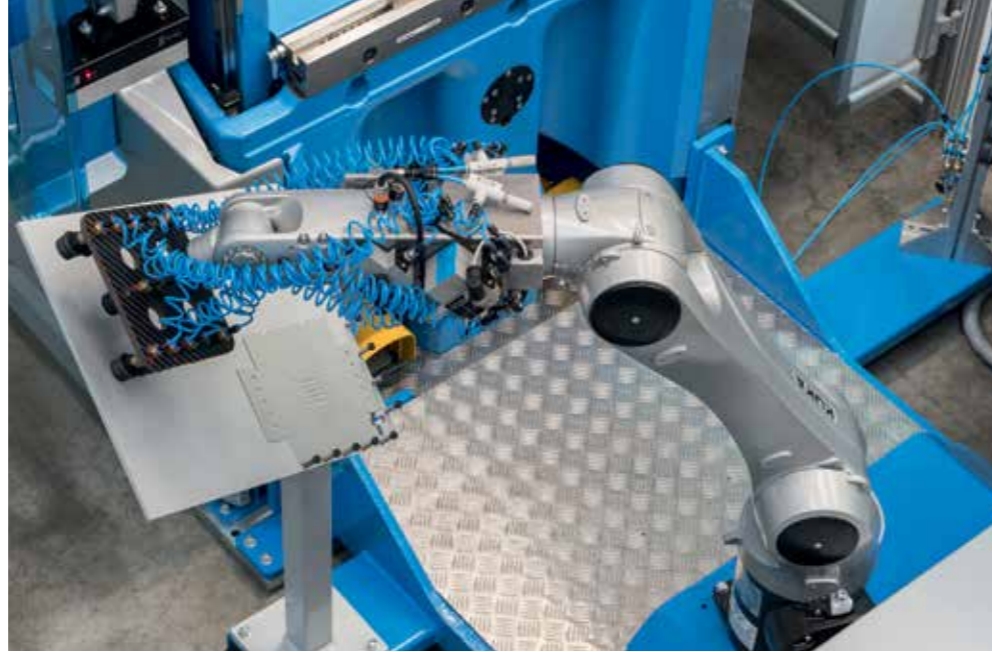

Maximum versatility of loading - unloading for any production requirement.

When designing a complete system, Euromac also paid great attention to the in-and outbound parts flow, to ensure a fast and reliable production. By anticipating multiple production needs, the FX bend cell offers a wide range of solutions for the loading-unloading operation.

Loading

Loading area with 2 pre-alignment tables. The pre-alignment table has a perforated die for the perfect positioning of the pieces. With different loading zones according to the model 1000 x 600, 1500 x 800, 2500 x 1000 mm. Optionally, we offer the possibility to have additional loading tables, to stack pieces next to a punching or a laser machine, and the easily moved to the cell with a forklift.

Unloading

Our automated work stations offer many unloading solutions, from palletization of parts on fixed europallets to 10 europallet automatic towers (kit of extra 5 optional pallets), to motorized roller conveyors for fast unloading operations. It is also possible to position pieces directly in cases or on a conveyor belt to unload on a fixed case, or positioned on motorized rollers.



COMBINATION OF UNLOADING Optional.

Belt conveyer unloading



Belt conveyer unloading with motorized boxes



Motorized Europallet unloading



GRIPPERS

Three examples of standard grippers. Additional gripper to make special customer parts on request.



Gripper* with vacuum for big format parts, external dimension 430x280 with the possibility to insert up to 8 suction cups.

Max nominal part weight: 1.5 Kg (centered position).



Gripper* with vacuum for medium format parts, external dimension 230x230 with the possibility to insert up to 10 suction cups.

Max nominal part weight: 5 Kg (centered position).



Gripper* with vacuum for small parts, with the possibility to insert from 3 up to 20 suction cups divided to maximum 8 independent zones.

Maximum nominal piece weight: 3 Kg. (in centered position).

**For a real feasibility is necessary to make a supplementary part inertia study where the part geometry is provided by the customer.*



APPLICATIONS

Quality and reliability of the pieces for a fast and high quality production.



FX bend cell is an automated bending cell combining production speed with high processing quality.

Active Fingers

For an accurate repeatability of the pieces with self-learning mode.

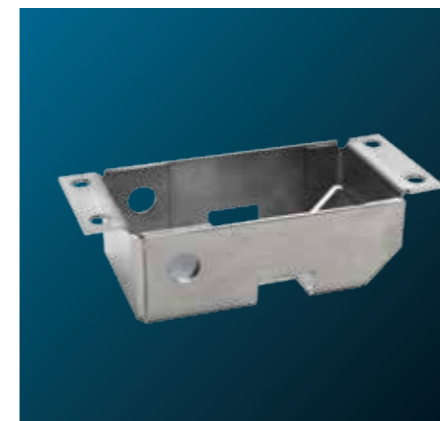



STANDARD 1023 / 1547

| technical data | cell 1023 | cell 1547 |
|---|--------------------|--------------------|
| Max. bending force (kN) | 230 | 470 |
| Bending length (mm) | 1020 | 1530 |
| Daylight opening | | |
| Wila clamping (die holder - to punch holder) (mm) | 315 | 360 |
| Promecam clamping (die holder - to ram) (mm) | 395 | 440 |
| Y axes stroke (mm) | 196 | 240 |
| Y axes speed (mm/sec) | 200 | 200 |
| Max. bending speed automatic mode (mm/sec) | 36 | 36 |
| Max. bending speed manual mode (mm/sec) | 10 | 10 |
| Robot | | |
| Max. reach (mm) | 1420 | 1420 |
| Max. payload with gripper (kg) | 10 | 10 |
| Number of axes | 6 | 6 |
| Pose repeability (mm) | +0.03 | +0.03 |
| FX Cell | | |
| Loading | | |
| Minimum parts dimension (mm) | 50 x 100 | 50 x 100 |
| Maximum stack height (mm) | 300 | 300 |
| Maximum thickness (mm) | 5 | 5 |
| Minimum thickness (mm) | 0,7 | 0,7 |
| Maximum part weight (kg) | 5 | 5 |
| Unloading | | |
| Belt conveyor buffer length (mm) | 600 unloading +600 | 600 unloading +600 |
| Area for gravity unloading (mm) | 1200 x 800 | 1200 x 800 |
| Connected load (kW) | 5 | 6 |
| Approx. weight (kg) | 3000 | 5000 |



PLUS 1023 / 1547

| technical data | cell 1023 | cell 1547 |
|---|--------------------|--------------------|
| Max. bending force (kN) | 230 | 470 |
| Bending length (mm) | 1020 | 1530 |
| Daylight opening | | |
| Wila clamping (die holder - to punch holder) (mm) | 315 | 360 |
| Promecam clamping (die holder - to ram) (mm) | 395 | 440 |
| Y axes stroke (mm) | 196 | 240 |
| Y axes speed (mm/sec) | 200 | 200 |
| Max. bending speed automatic mode (mm/sec) | 36 | 36 |
| Max. bending speed manual mode (mm/sec) | 10 | 10 |
| Robot | | |
| Max. reach (mm) | 1420 | 1420 |
| Max. payload with gripper (kg) | 10 | 10 |
| Number of axes | 6 | 6 |
| Pose repeability (mm) | +0.03 | +0.03 |
| FX Cell | | |
| Loading | | |
| Minimum parts dimension (mm) | 50 x 100 | 50 x 100 |
| Maximum stack height (mm) | 300 | 300 |
| Maximum thickness (mm) | 5 | 5 |
| Minimum thickness (mm) | 0,7 | 0,7 |
| Maximum part weight (kg) | 5 | 5 |
| Unloading | | |
| Belt conveyor buffer length (mm) | 600 unloading +600 | 600 unloading +600 |
| Area for gravity unloading (mm) | 1200 x 800 | 1200 x 800 |
| Connected load (kW) | 5 | 6 |
| Approx. weight (kg) | 3000 | 5500 |



MAX 1023 / 1547

| technical data | cell 1023 | cell 1547 |
|---|--------------------|--------------------|
| Max. bending force (kN) | 230 | 470 |
| Bending length (mm) | 1020 | 1530 |
| Daylight opening | | |
| Wila clamping (die holder - to punch holder) (mm) | 315 | 360 |
| Promecam clamping (die holder - to ram) (mm) | 395 | 440 |
| Y axes stroke (mm) | 196 | 240 |
| Y axes speed (mm/sec) | 200 | 200 |
| Max. bending speed automatic mode (mm/sec) | 36 | 36 |
| Max. bending speed manual mode (mm/sec) | 10 | 10 |
| Robot | | |
| Max. reach (mm) | 1420 | 1420 |
| Max. payload with gripper (kg) | 10 | 10 |
| Number of axes | 6 | 6 |
| Pose repeability (mm) | +0.03 | +0.03 |
| FX Cell | | |
| Loading | | |
| Minimum parts dimension (mm) | 50 x 100 | 50 x 100 |
| Maximum stack height (mm) | 300 | 300 |
| Maximum thickness (mm) | 5 | 5 |
| Minimum thickness (mm) | 0,7 | 0,7 |
| Maximum part weight (kg) | 5 | 5 |
| Unloading | | |
| Belt conveyor buffer length (mm) | 600 unloading +600 | 600 unloading +600 |
| Area for gravity unloading (mm) | 1200 x 800 | 1200 x 800 |
| Connected load (kW) | 5 | 6 |
| Approx. weight (kg) | 3000 | 6000 |

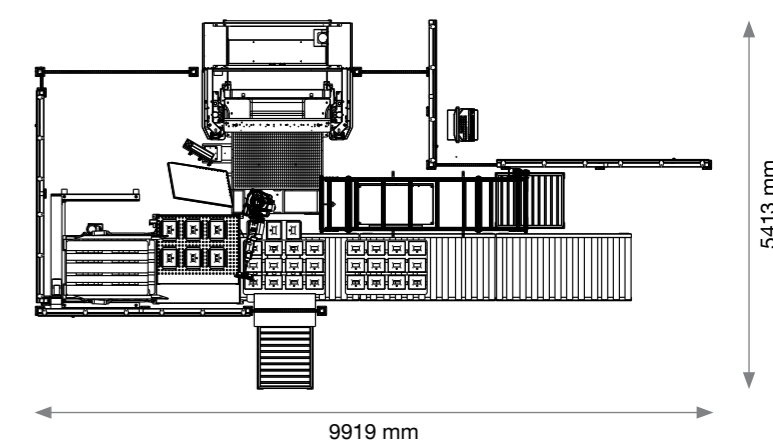
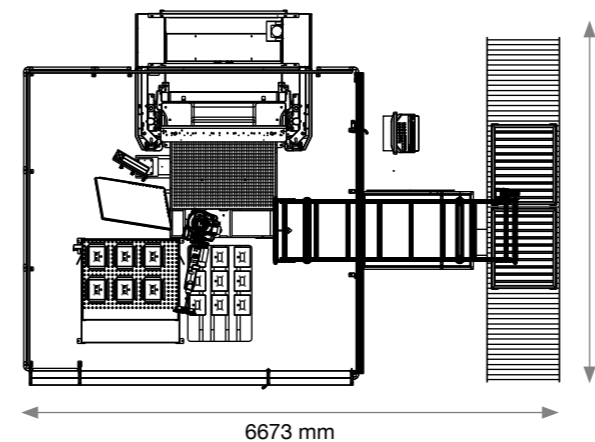
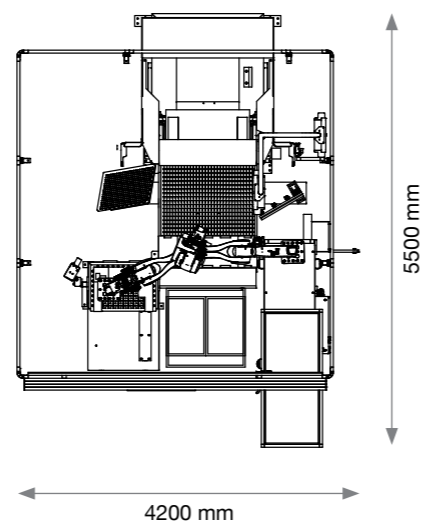



STANDARD KR60

| technical data | cell 1547 |
|---|---------------------|
| Max. bending force (kN) | 470 |
| Bending length (mm) | 1530 |
| Daylight opening | |
| Wila clamping (die holder - to punch holder) (mm) | 360 |
| Promecam clamping (die holder - to ram) (mm) | 440 |
| Y axes stroke (mm) | 240 |
| Y axes speed (mm/sec) | 200 |
| Max. bending speed automatic mode (mm/sec) | 36 |
| Max. bending speed manual mode (mm/sec) | 10 |
| Robot | |
| Max. reach (mm) | 2233 |
| Max. payload with gripper (kg) | 60 |
| Number of axes | 6 |
| Pose repeability (mm) | +/-0.06 |
| FX Cell | |
| Loading | |
| Maximum parts dimension 1 stack (mm) | 1500 x 800 |
| Minimum parts dimension (mm) | 50 x 100 |
| Maximum stack height (mm) | 300 |
| Maximum thicknes (mm) | 5 |
| Minimum thicknes (mm) | 0,7 |
| Maximum part weight (kg) | 30 |
| Unloading | |
| Belt conveyor Max. parts dimension (mm) | 1000 x 600 x h 300 |
| Belt conveyor buffer length (mm) | 600 unloading + 600 |
| Area for gravity unloading (mm) | 1200 x 800 |
| Connected load (kWa) | 6 |
| Approx. weight (kg) | 6200 |



MAX KR60

| technical data | cell 1547 |
|---|---------------------|
| Max. bending force (kN) | 470 |
| Bending length (mm) | 1530 |
| Daylight opening | |
| Wila clamping (die holder - to punch holder) (mm) | 360 |
| Promecam clamping (die holder - to ram) (mm) | 440 |
| Y axes stroke (mm) | 240 |
| Y axes speed (mm/sec) | 200 |
| Max. bending speed automatic mode (mm/sec) | 36 |
| Max. bending speed manual mode (mm/sec) | 10 |
| Robot | |
| Max. reach (mm) | 2233 |
| Max. payload with gripper (kg) | 60 |
| Number of axes | 6 |
| Pose repeability (mm) | +/-0.06 |
| FX Cell | |
| Loading | |
| Maximum parts dimension 1 stack (mm) | 1500 x 800 |
| Minimum parts dimension (mm) | 50 x 100 |
| Maximum stack height (mm) | 300 |
| Maximum thicknes (mm) | 5 |
| Minimum thicknes (mm) | 0,7 |
| Maximum part weight (kg) | 30 |
| Unloading | |
| Belt conveyor Max. parts dimension (mm) | 1000 x 600 x h 300 |
| Belt conveyor buffer length (mm) | 600 unloading + 600 |
| Area for gravity unloading (mm) | 1200 x 800 |
| Connected load (kWa) | 6 |
| Approx. weight (kg) | 7000 |

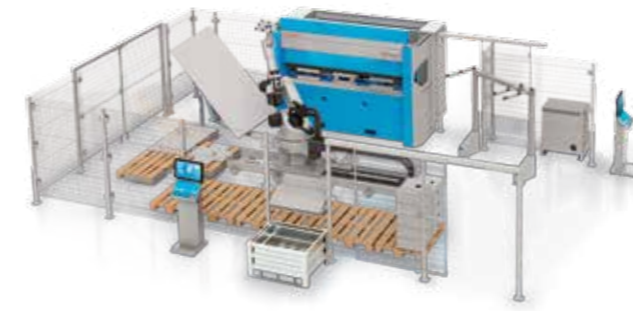

STANDARD 2560

| technical data | cell 2560 |
|---|-------------|
| Max. bending force (kN) | 500 / 600 |
| Bending length (mm) | 2550 |
| Daylight opening | |
| Wila clamping (die holder - to punch holder) (mm) | 360 |
| Promecam clamping (die holder - to ram) (mm) | 440 |
| Y axes stroke (mm) | 240 |
| Y axes speed (mm/sec) | 200 |
| Max. bending speed automatic mode (mm/sec) | 36 |
| Max. bending speed manual mode (mm/sec) | 10 |
| Robot | |
| Max. reach (mm) | 2233 |
| Max. payload with gripper (kg) | 60 |
| Number of axes | 7 |
| Pose repeability (mm) | +/-0.06 |
| FX Cell | |
| Loading | |
| Maximum parts dimension 1 stack (mm) | 2500 x 1000 |
| Minimum parts dimension (mm) | 50 x 100 |
| Maximum stack height (mm) | 300 |
| Maximum thicknes (mm) | 5 |
| Minimum thicknes (mm) | 0,7 |
| Maximum part weight (kg) | 30 |
| Unloading | |
| Area for gravity unloading (mm) | 1200 x 800 |
| Connected load (kWa) | 6 |
| Approx. weight (kg) | 8500 |



MAX 2560

| technical data | cell 2560 |
|---|-------------|
| Max. bending force (kN) | 500 / 600 |
| Bending length (mm) | 2550 |
| Daylight opening | |
| Wila clamping (die holder - to punch holder) (mm) | 360 |
| Promecam clamping (die holder - to ram) (mm) | 440 |
| Y axes stroke (mm) | 240 |
| Y axes speed (mm/sec) | 200 |
| Max. bending speed automatic mode (mm/sec) | 36 |
| Max. bending speed manual mode (mm/sec) | 10 |
| Robot | |
| Max. reach (mm) | 2233 |
| Max. payload with gripper (kg) | 60 |
| Number of axes | 7 |
| Pose repeability (mm) | +/-0.06 |
| FX Cell | |
| Loading | |
| Maximum parts dimension 1 stack (mm) | 2500 x 1000 |
| Minimum parts dimension (mm) | 50 x 100 |
| Maximum stack height (mm) | 300 |
| Maximum thicknes (mm) | 5 |
| Minimum thicknes (mm) | 0,7 |
| Maximum part weight (kg) | 30 |
| Unloading | |
| Area for gravity unloading (mm) | 1200 x 800 |
| Connected load (kWa) | 6 |
| Approx. weight (kg) | 9500 |

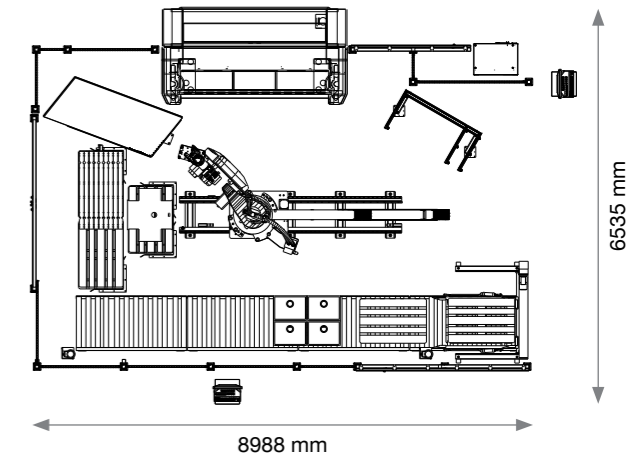
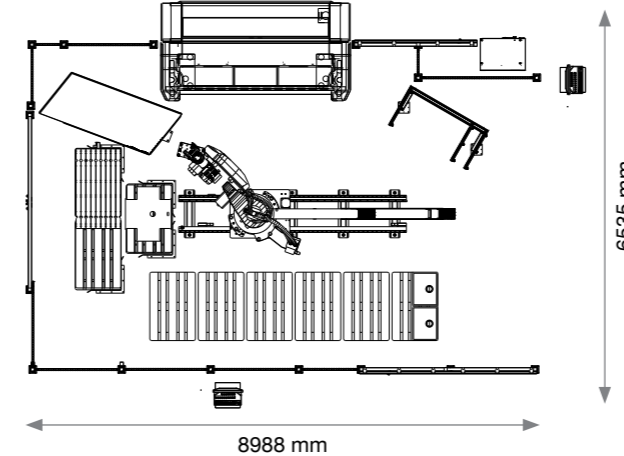
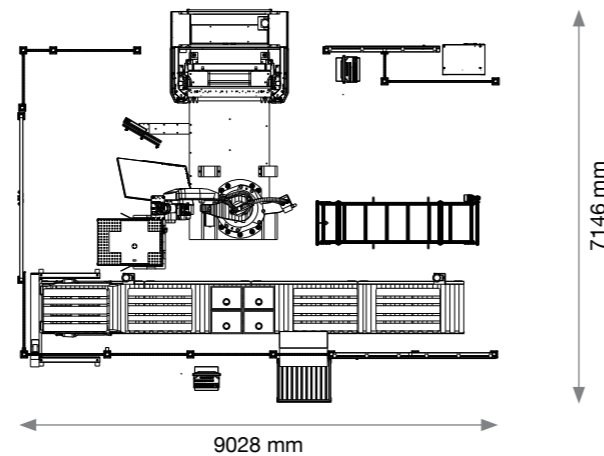
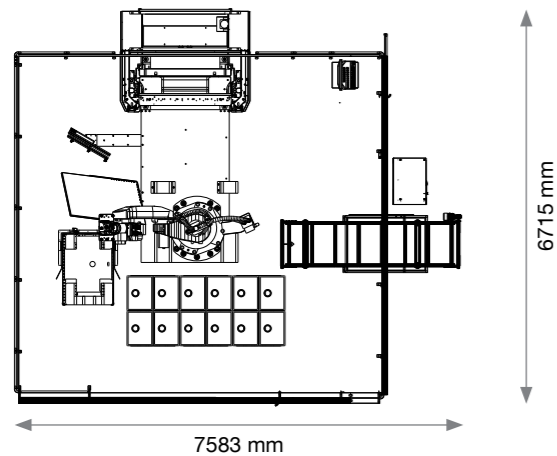



sheet metal working center

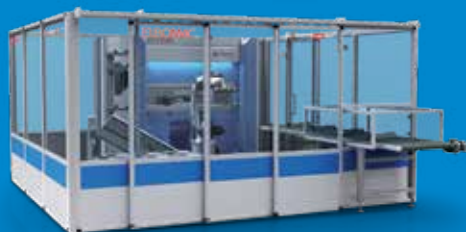

automated electric press brake



electric press brake



horizontal bending machines



notching machines

EUROMAC®

Euromac S.p.A.
Via per Sassuolo, 68/g
41043 Formigine (MO) - Italy
Tel. +39 059 579511
Fax +39 059 579512
info@euromac.it



PRODUCED & ASSEMBLED
IN ITALY BY EUROMAC

www.euromac.com

Disclaimer. Actual product may differ slightly from images shown in this catalogue. All information and data on this catalogue is subject to change without notice.